

CMP Attachments, LLC.

HYDRA GRAPPLE

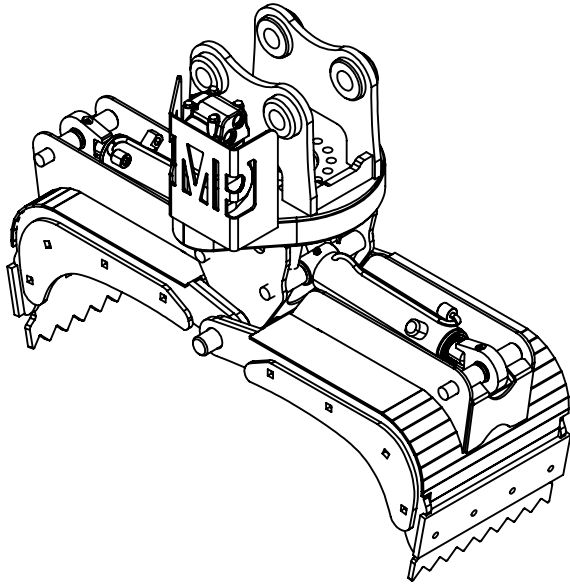

MODEL:	61
MAX OPEN:	40 1/2"
MIN CLOSED:	10 3/8"
VOLUME OPENED:	3.75 FT ³
VOLUME CLOSED:	2 1/4 FT ³
CYLINDER BORE:	2 1/2"
MAX PRESSURE:	4,500 PSI
MAX TORQUE:	7,500 IN-LB
MACHINE WEIGHT:	6,000-10,000 LBS
APPROXIMATE WEIGHT:	475 LBS
OPTIONS:	CLOSED SIDE EDGES

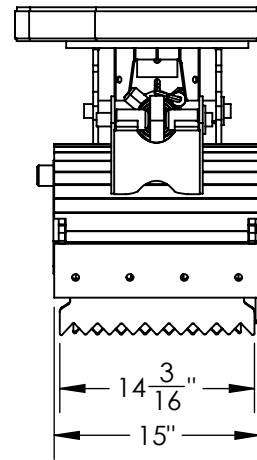
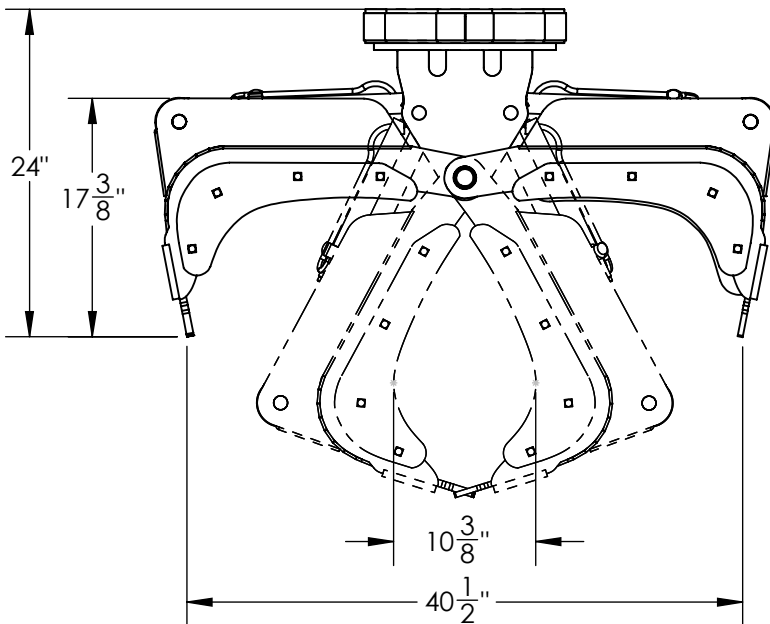

Features

- Single rotational drive motor provides intense rotational torque.
- Motor has built in cross relief which serves as a cushion when stopping rotation under load.
- Heavy duty AR-400 hardened steel with 177,000lb tensile strength and Rockwell hardness of 440.
 - High strength body made from T1 steel is three times stronger than standard steel.
- Stress proof bolts are able to withstand tremendous amounts of flexing and fatigue long term.
 - Excavator tooth bar is ideal for excavating or grabbing boulders and other large objects.
- Electronic control valve option eliminates the need for expensive secondary auxiliary hydraulics on an excavator.
 - Rigid quality control during manufacturing ensures reliability.
 - Completely fabricated in our facility in Clear Lake Minnesota.